

News

Salone Internazionale  
del Bagno 2022, Milano

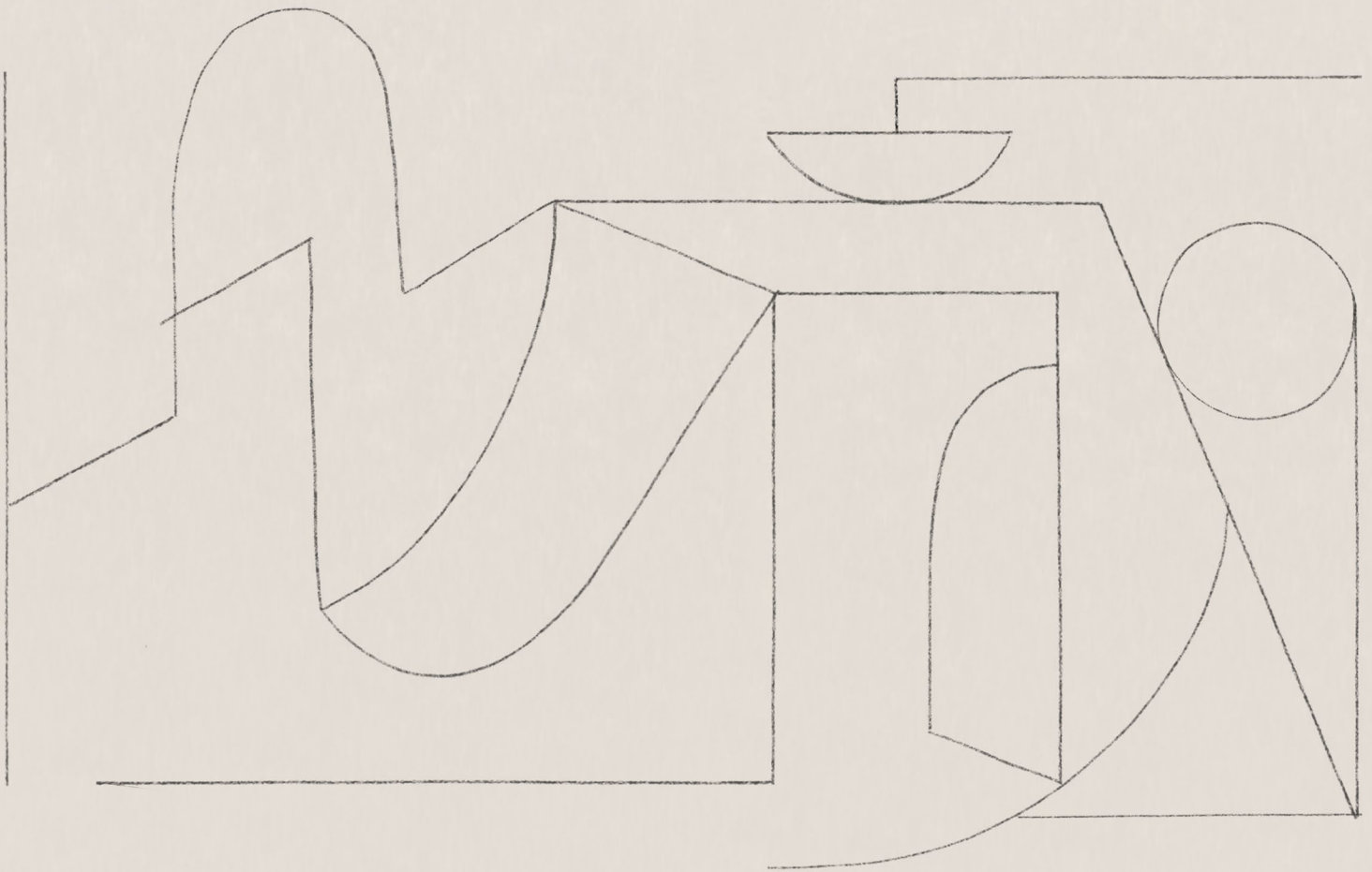

noorth

milldue edition

News

## Salone Internazionale del Bagno 2022, Milano

Introduction  
Fjord Collection  
Saba Collection  
Caba Collection  
Azuco Collection  
Puro Collection  
Sintesi Collection  
Touch Collection

noorth

milldue edition



Dalle nuove collezioni Azuco, Saba e Caba dello studio spagnolo Altherr Désile Park fino ai nuovi componenti e alle nuove finiture di collezioni già note, come Fjord, di Giuseppe Bavuso, e Puro, Sintesi e Touch, di Michele Marcon. Una varietà di soluzioni diverse per stile, tipologia e logica compositiva, pensata per garantire una progettazione ideale dell'ambiente bagno contemporaneo.

A wide range of new solutions, varying in style, typology, and compositional logic, designed to ensure an ideal design of the contemporary bathroom: the new collections Azuco, Saba, and Caba, designed by the Spanish studio Altherr Désile Park, together with new components and finishes of the iconic collections Fjord, designed by Giuseppe Bavuso, and Puro, Sintesi and Touch, designed by Michele Marcon.



L'allestimento si presenta come uno spazio aperto, dall'impatto semplice e immediato. Protagonisti nella zona centrale i nuovi lavabi freestanding Saba, declinati in diverse varianti di materiali e finiture, mentre le collezioni Azuco e Fjord, e più avanti Puro, Sintesi e Touch, sono ambientate in aree dedicate.

The Noorth booth was designed as an open space with a simple and immediate impact. The central area featured Saba, a new freestanding washbasin available in a variety of materials and finishes, while dedicated areas featured the collections Azuco and Fjord, as well as Puro, Sintesi and Touch.



# Fjord

design Giuseppe Bavuso

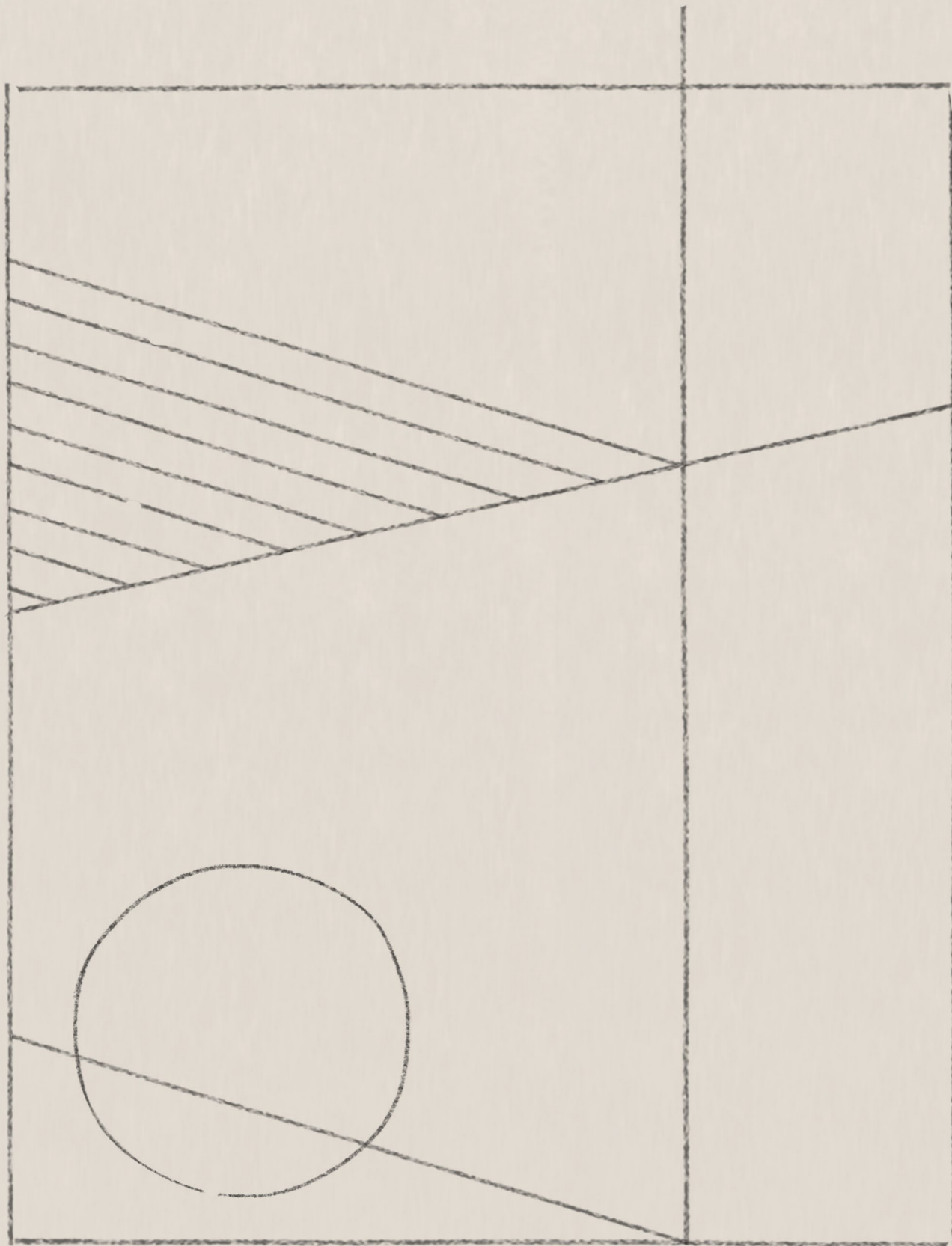

Un sistema componibile ad alte prestazioni, basato su una struttura in alluminio e un insieme di attrezzature e accessori esclusivi: contenitori a cassetti in essenza o laccati, vani a giorno, piani lavabo, specchiere e mensole attrezzate. Prevista in origine nella versione sospesa a parete, la collezione è completata da una recente soluzione freestanding, prevista in diverse configurazioni.

A high-performance modular system based on an aluminum structure and a set of exclusive equipments and accessories: wooden or lacquered drawer cabinets, open units, countertops, mirrors and equipped shelves. Originally planned in a wall-hung version, the collection is completed by a recent freestanding solution, provided in different configurations.



Il disegno essenziale del top con lavabo e cassetto integrati è ottenuto grazie alla particolare lavorazione a 45° del bordo.

The essential design of the top with integrated washbasin and integrated drawer is achieved thanks to the special 45° machining of the edge.



#### Freestanding Fjord

Top integrato e cassetto laterale in marmo Grafite. Basi con struttura, cassetto e vano a giorno in laccato metallizzato Quarzo. Specchiera Kara con retroilluminazione LED tre lati. Mensola Ljos in alluminio laccato Quarzo completa di accessori e retroilluminazione inferiore LED. Rubinetteria Flow L03 in acciaio inox PVD nero. Tappeto Lidi O6-W.

#### Freestanding Fjord

Integrated top and side drawer in Grafite marble. Base units with structure, drawer and open vanity in Quarzo metallic lacquer. Kara mirror with three-sided LED backlighting. Ljos shelf in Quarzo lacquered aluminium complete with accessories and lower LED backlighting. Flow L03 tap in black PVD stainless steel. Lidi O6-W carpet.







Pratici e funzionali, i contenitori a 2 cassetti sono disponibili in tutti i legni della collezione Noorth. Nella finitura in noce e' prevista la variante con lavorazione con incastro a pettine.

Practical and functional, the 2-drawer storage units are available in all woods from Noorth chart. In the walnut finish, there is a variant finger joint system.



Suspended Fjord  
Top integrato Finn 70 in Milltek Solid attrezzato con vassoi portaoggetti in Rovere Nero. Elemento a giorno con struttura in alluminio laccato Platino e listelli in Rovere Nero. Basi due cassetti con maniglia fresata in Rovere Nero. Mensola Ljos in alluminio laccato Platino, completa di accessori e retroilluminazione LED. Specchiera Ekos V con retroilluminazione a LED quattro lati e illuminazione a LED due lati verticali interni. Rubinetteria Flow L02 in acciaio inox satinato. Tappeto Plain 03-B.

Suspended Fjord  
Finn 70 integrated top in Milltek Solid equipped with storage trays in Rovere Nero. Open element with Platino lacquered aluminium structure and Rovere Nero strips. Two-drawer base units with milled handle in Black Oak. Ljos shelf in Platino lacquered aluminium, complete with accessories and LED backlighting. Ekos V mirror with LED backlighting four sides and LED lighting two vertical internal sides. Flow L02 tapware in brushed stainless steel. Plain 03-B carpet.



Le nuove composizioni freestanding:  
un'immagine rigorosa, valorizzata dalla qualità  
delle attrezzature, dai contenitori a cassetti alle  
diverse versioni dei ripiani del sistema.

The new freestanding compositions:  
a rigorous image, enhanced by the quality  
of the equipment, from the drawers units to  
the different versions of the shelves.

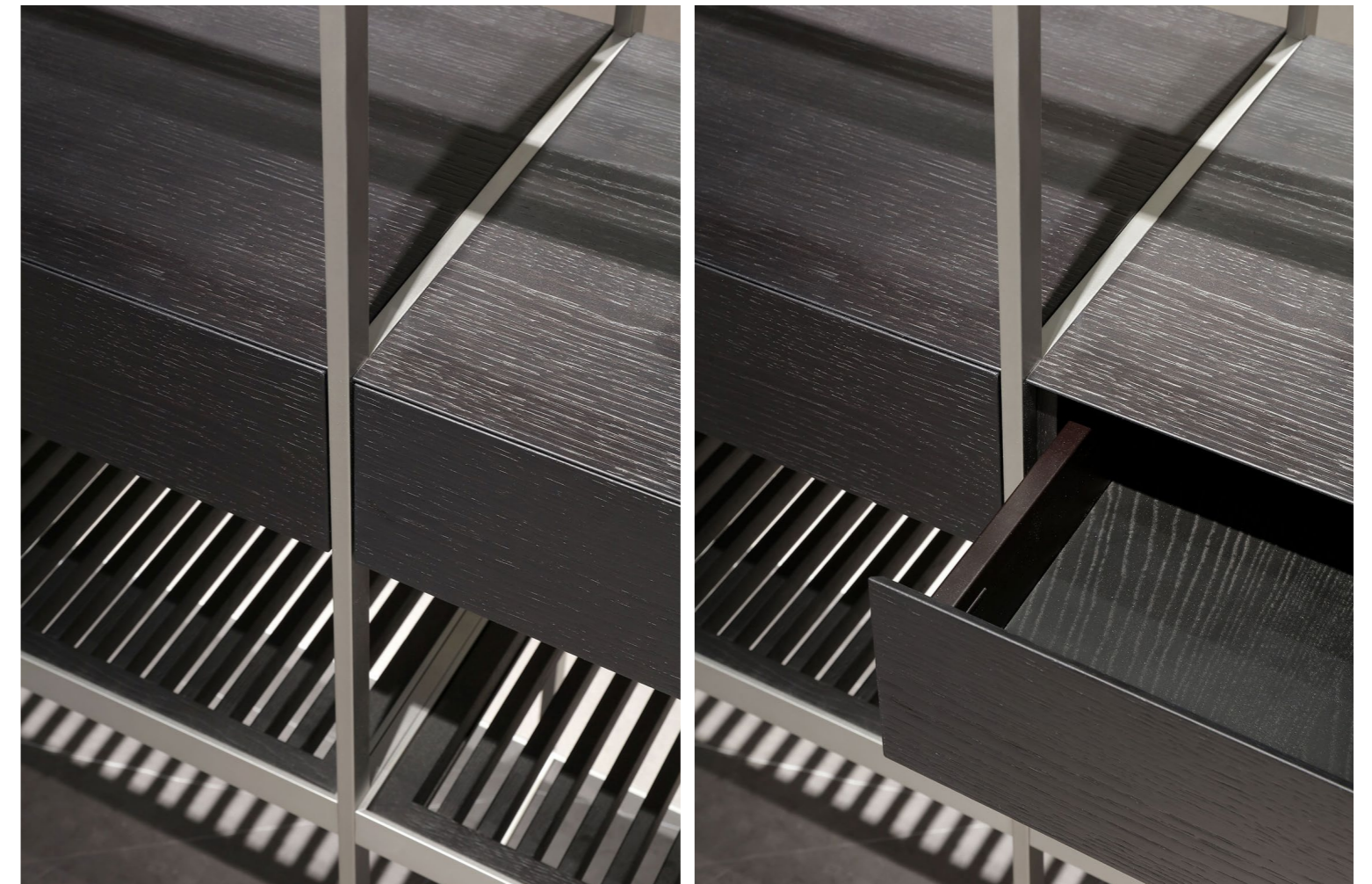

Freestanding shelves Fjord  
Libreria free-standing con struttura in alluminio  
laccato Platino, cassetti in Rovere Nero, ripiani  
in vetro Fumè, listelli in Rovere Nero e marmo  
Grafite.

Freestanding shelves Fjord  
Free-standing bookcase with structure in Platino  
lacquered aluminium, drawers in Rovere Nero,  
shelves in Smoked glass, strips in Rovere Nero  
and Grafite marble.

## BASI FREESTANDING | FREESTANDING BASES

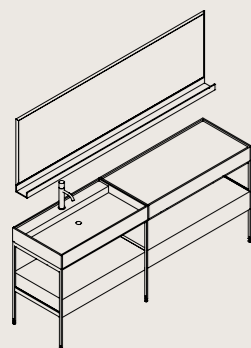

Pratica e funzionale, la nuova versione con appoggio a terra amplia le possibilità compositive del sistema.

Practical and functional, the new floor mounted version expands the compositional possibilities of the system.

## TOP CON LAVABO E CASSETTO INTEGRATI | TOP WITH INTEGRATED WASHBASIN AND DRAWER

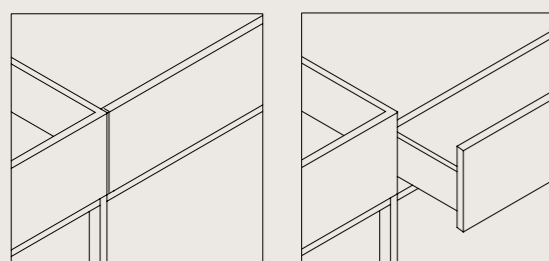

Previsto in versione monomaterica, in corian e nei 7 marmi della collezione.

Provided in single-material versions, in corian and in the 7 marbles available in the collection.

## KARA, SPECCHIERA CON CORNICE RETROILLUMINATA | KARA, MIRROR WITH BACKLIT FRAME

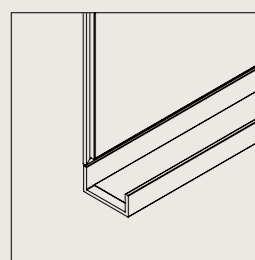

Disponibile nelle diverse finiture metallizzate della collezione Fjord, la specchiera Kara consente un ideale abbinamento con le mensole Ljos.

Available in the different metallic finishes of the Fjord collection, the Kara mirror allows for an ideal combination with the Ljos shelves.

## MAGGIORE VARIETÀ NELLE FINITURE | MORE FINISHES OPTIONS

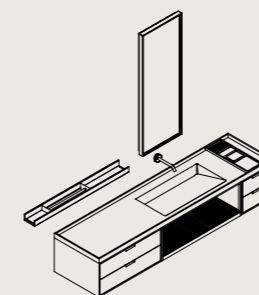

essenze | veneers

rovere  
mezza fiamma

rovere  
miele

rovere  
termocotto

rovere  
nero

rovere  
tundra

noce  
canaletto

rovere  
carbone

I moduli a 2 cassetti e i ripiani a listelli sono disponibili in tutte le essenze sopra riportate. La versione in noce è disponibile anche con incastro a pettine.

Two-drawers units and slats shelves are available in all the above veneers. The Noce version is available also with finger joint system.

## CONTENITORI FREESTANDING | FREESTANDING SHELVES

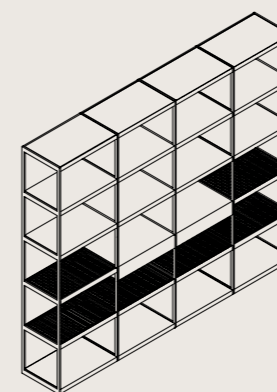

Previsti in diverse composizioni dei moduli 54 e 72cm, fino alla lunghezza di 216cm. Liberamente attrezzabili con i contenitori a cassetti e le diverse versioni di ripiani.

Available in different units composition of length 54 and 72 cm, until length 216 cm. Freely equippable with drawer units and different versions of the shelves.

# Saba

design Altherr Désile Park

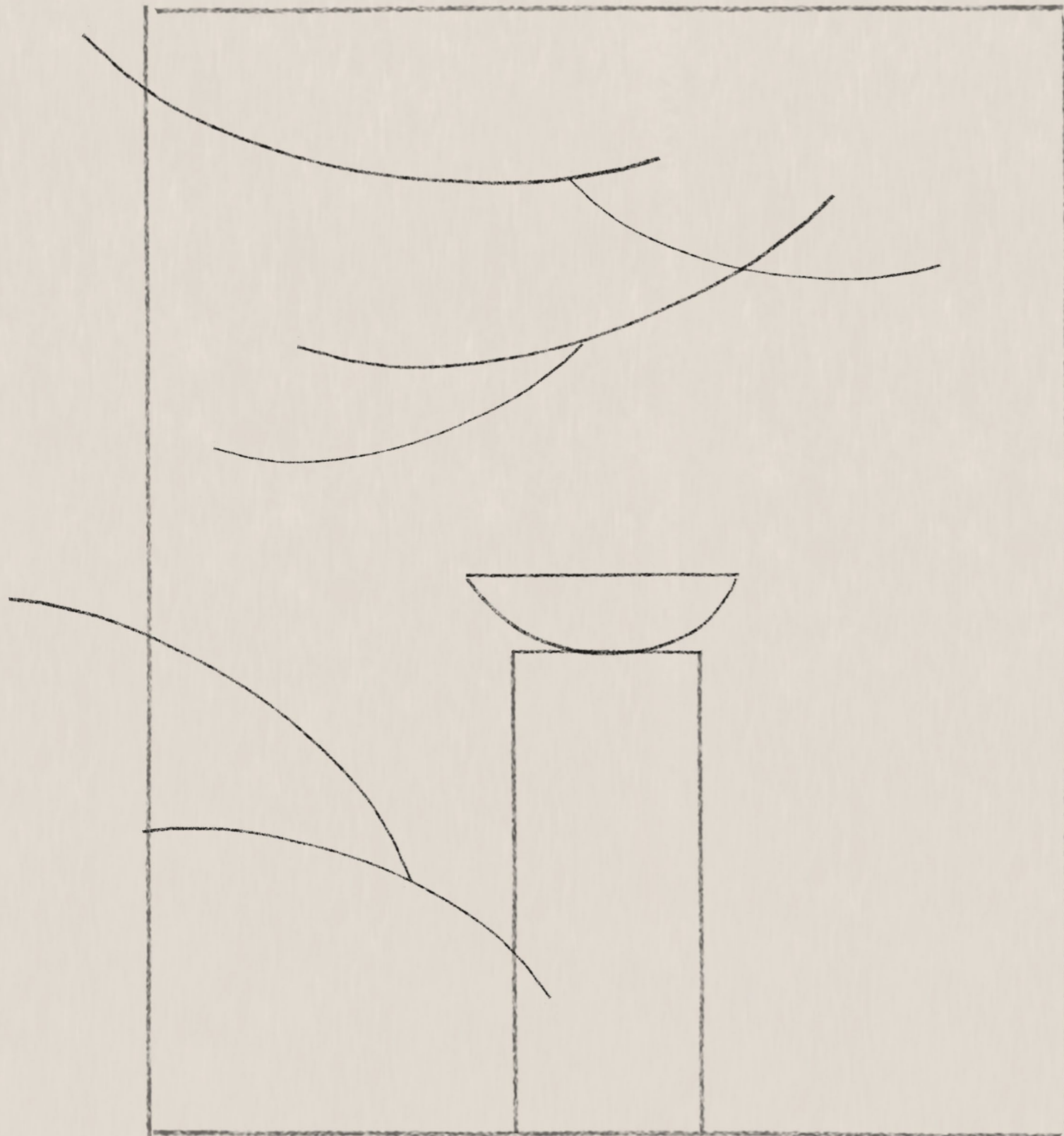

Saba è un lavabo freestanding dall'immagine semplice e immediata. La sua forma archetipica e minimalista consente l'uso di finiture e materiali diversi, suggerendo un libero inserimento in contesti indoor e outdoor. I lavabi Saba sono previsti in marmo, cemento, argilla e laccato, in versione monomaterica o con base nelle diverse essenze lignee della collezione.

Saba is a column washbasin with a timeless feel, quite a statement in its radical simplicity. Its minimalist archetype shape allows the use of different finishes and materials, fitting in both indoor and outdoor settings. Saba washbasins are available in marble, concrete, clay and lacquered, in a single material version or with a base in the different wood essences of the collection.





Marmo, cemento, e quest'ultimo rivestito in argilla o laccato: la libertà di scegliere tra un'ampia varietà di finiture e colori rappresenta una qualità distintiva del progetto Saba.

Marble and concrete. The latter covered in lacquer finish or clay: the freedom of choosing between a wide variety of finishes and colours shows a distinctive quality of Saba project.



pagina precedente: Saba 45 in cemento Caolino. Saba 37 in marmo nero Marquina. Saba 37 in cemento Antracite. Accessori Zeno.

previous page: Saba 45 in Caolino cement. Saba 37 in Nero Marquina marble. Saba 37 in Antracite cement. Zeno accessories.

a destra: Saba 37 in argilla Rosso Bollo. Saba 37 in argilla Senape. Accessori Zeno. Rubinetteria in acciaio inox PVD nero.

on the right: Saba 37 in Rosso Bollo clay. Saba 37 in Senape clay. Zeno accessories. Faucets in black PVD stainless steel.

pagina successiva: Saba 37 con fusto in Noce Canaletto e lavabo in Marmo Grafite. Saba 45 in cemento Caolino. Saba 45 con fusto in Rovere Mezza Fiamma e lavabo in cemento laccato Creta. Saba 37 in argilla Rosso Bollo. Saba 45 con fusto in Rovere Carbone e lavabo in argilla Senape. Saba 45 in laccato Nero opaco. Saba 37 in marmo Carrara. Saba 37 in cemento Antracite.

next page: Saba 37 with column in Noce Canaletto and Marmo Grafite washbasin. Saba 45 in Caolino cement. Saba 45 with column in Rovere Mezza Fiamma and Creta lacquered cement washbasin. Saba 37 in Rosso Bollo clay. Saba 45 with column in Rovere Carbone and Senape clay washbasin. Saba 45 in Black lacquered cement. Saba 37 in Carrara marble. Saba 37 in Antracite cement.



## UN NUOVO LAVABO FREESTANDING | A NEW FREESTANDING WASHBASIN

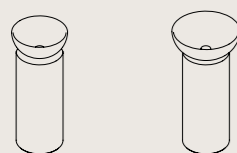

Dedicato agli spazi indoor e outdoor, con ciotola lavabo disponibile con diametro 37 e 45 cm.

Dedicated to indoor and outdoor spaces, with sink bowl available with diameter 37 and 45 cm.

## ZENO ACCESSORI | ZENO ACCESSORIES

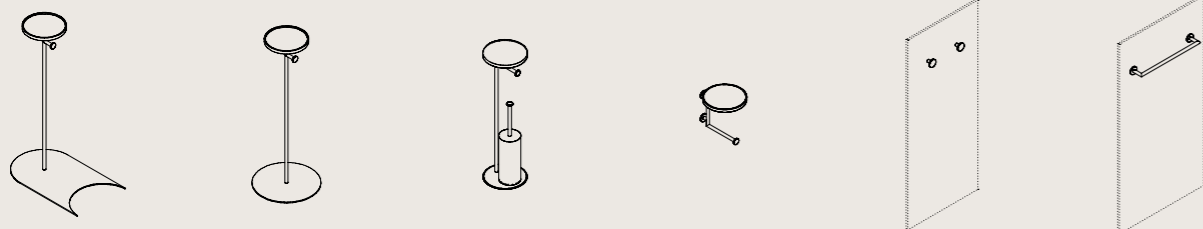

Essenziale nel disegno, prevista nella finitura in laccato nero opaco, la proposta è abbinabile ai lavabi e ai contenitori della collezione Noorth.

Essential in design, provided in black matt lacquer, the proposal can be combined with the washbasins and units from the Noorth collection.

## LE FINITURE | FINISHES

new

### lavabo, base | washbasin, unit

#### cemento | concrete



#### argille | clays



#### marmi opachi | matt marbles

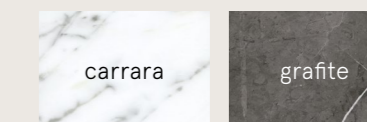

#### laccati opachi | matt lacquered

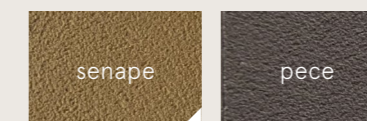
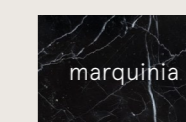
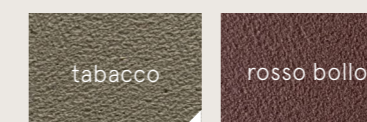
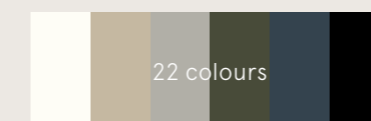

### base | unit

#### essenze | veneers

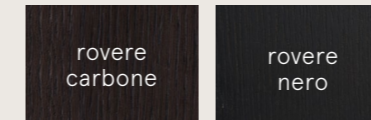
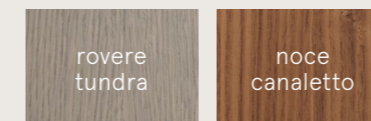
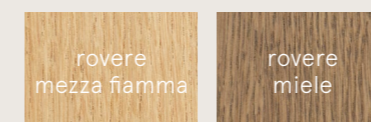

### accessori Zeno | Zeno accessories

#### laccati | lacquered

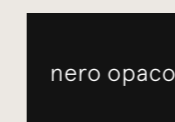

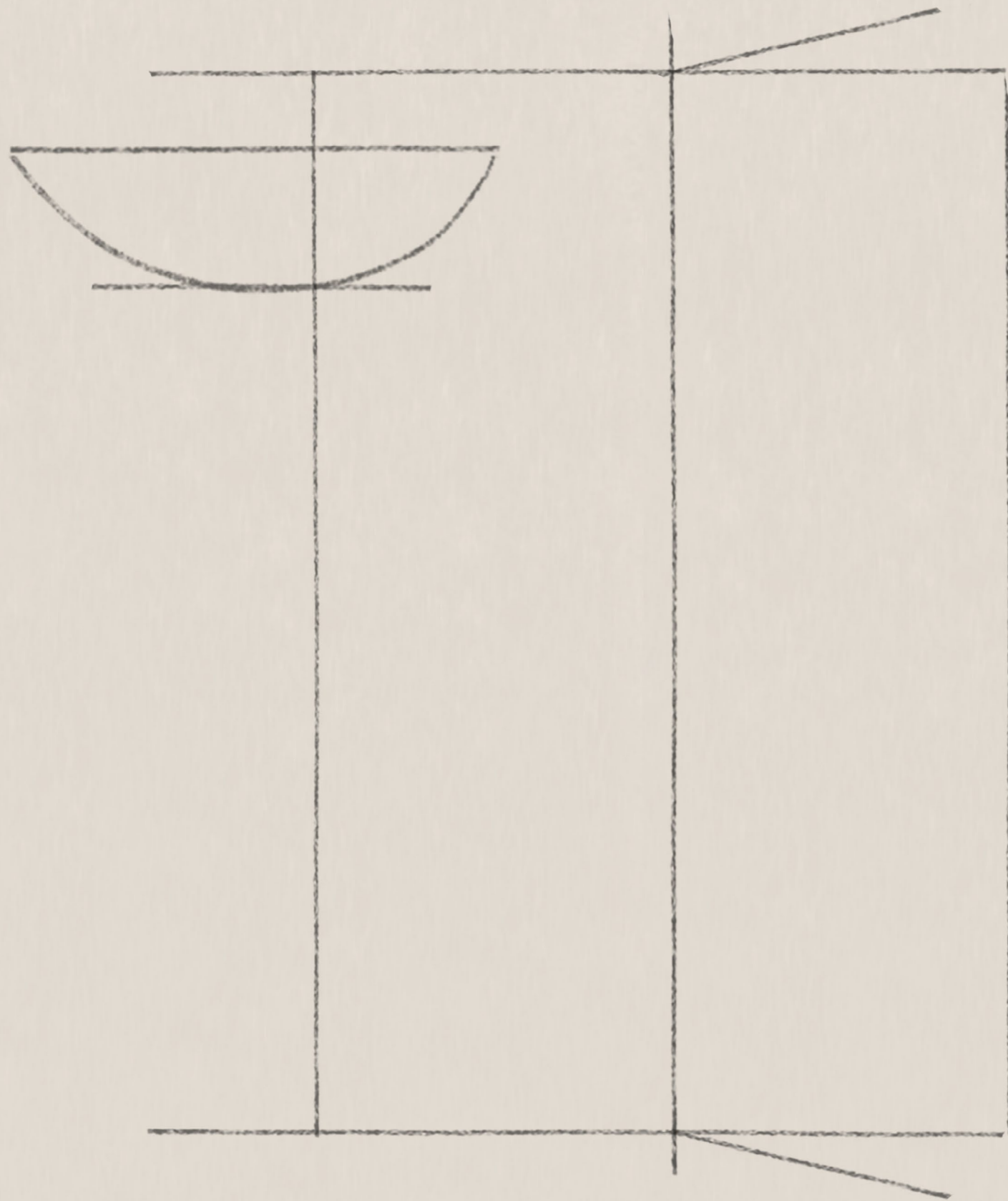

# Caba

design Altherr Désile Park

Semplice, versatile, funzionale: il sistema di contenitori Caba risolve le tipiche esigenze di contenimento dell'ambiente bagno. L'ingombro minimo degli elementi e la varietà delle finiture offrono un richiamo alla classicità della boiserie, mentre le versioni integrate alla zona lavabo e sanitari lo rendono adatto ad ogni progetto.

Smooth, versatile, functional: the Caba storage system solves the typical containment needs of the bathroom environment. The minimal size of the elements and the variety of finishes resemble the classicism of the wall paneling, the functionality of the equipped compartment between the base and wall units, while the integrated versions with the washbasin or sanitaryware make it suitable for any project.



Liberamente componibile in larghezza, il sistema Caba prevede un modulo con rubinetteria integrata che permette di attrezzare in modo funzionale la zona lavabo.

Freely modular in width, Caba system includes a unit with integrated taps, that allows you to equip the washbasin area in a functional way.



Caba + Saba  
Basi Caba contenitori in Rovere Mezza Fiamma.  
Saba 45 con fusto in Rovere Mezza Fiamma e  
lavabo cemento laccato Creta. Specchiera Air  
con retroilluminazione LED. Rubinetteria Flow L01  
in acciaio inox PVD nero. Portasciugamani Zeno  
laccato nero opaco.

Caba + Saba  
Caba base units in Rovere Mezza Fiamma. Saba  
45 with column in Rovere Mezza Fiamma and  
Creta lacquered cement washbasin. Air mirror  
with LED backlighting. Flow L01 taps in black PVD  
stainless steel. Zeno towel holder in matt black



Massimo contenimento nella composizione dotata di pensili e basi e attrezzate per i sanitari. Completano la proposta gli accessori della collezione Zeno.

Maximum storage in the composition equipped with wall and base units and equipped for the sanitary ware. Complete the proposal the accessories from the Zeno collection.



Caba + Sintesi  
Contenitori Caba in Venato Sesamo.  
Accessori Zeno laccato nero opaco.

Caba + Sintesi  
Caba storage units in Venato Sesamo.  
Zeno Accessories matt black lacquered.



## UN NUOVA SOLUZIONE PER IL CONTENIMENTO | NEW STORAGE SOLUTION

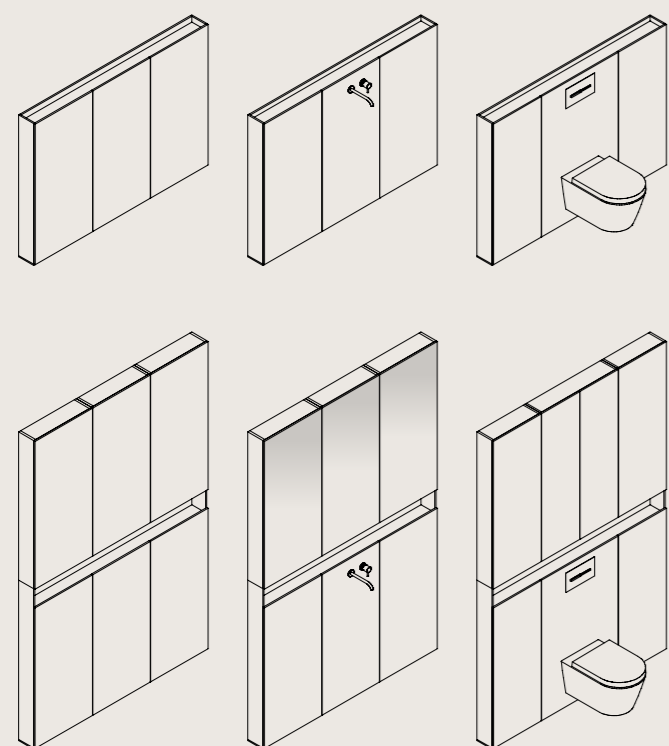

Tanto semplice quanto innovativo. Caba risolve le tipiche esigenze di contenimento del bagno con una serie di contenitori della minima profondità di 16cm, liberamente componibili. Il sistema prevede l'integrazione delle tipiche attrezzature dell'ambiente bagno, come rubinetteria e sanitari.

As simple as innovative, Caba solves the typical bathroom containment needs with a series of units with minimum depth of 16cm, freely modular. The system provides the integration of the typical equipment of the environment bathroom, such as taps and sanitary ware.

## LE FINITURE | FINISHES

new

### nobilitato | faced panels



### Sillmatt



### laccati opachi e lucidi spazzolati | matt lacquered and high glossy lacquered

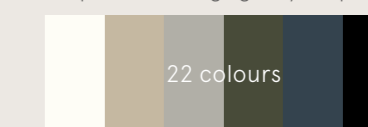

### laccati metallizzati | metallic lacquered

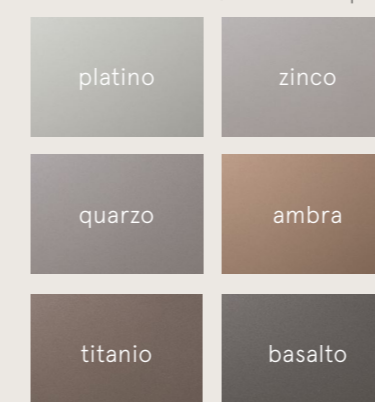

### argille | clays



### essenze | veneers

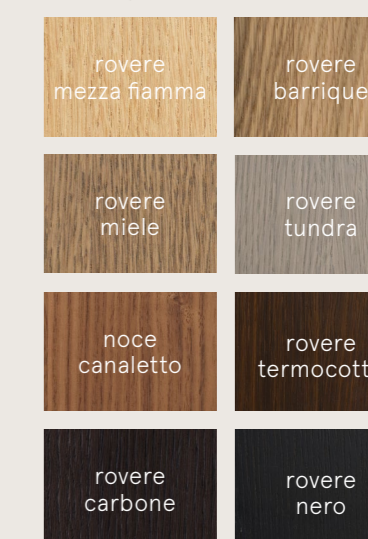

Essenze, laccati, melaminici: la versatilità di Caba è confermata dalla varietà delle finiture previste.

Veneers, lacquers, faced panels: the versatility of Caba is confirmed by the variety of finishes provided.

# AzucO

design Altherr Désile Park

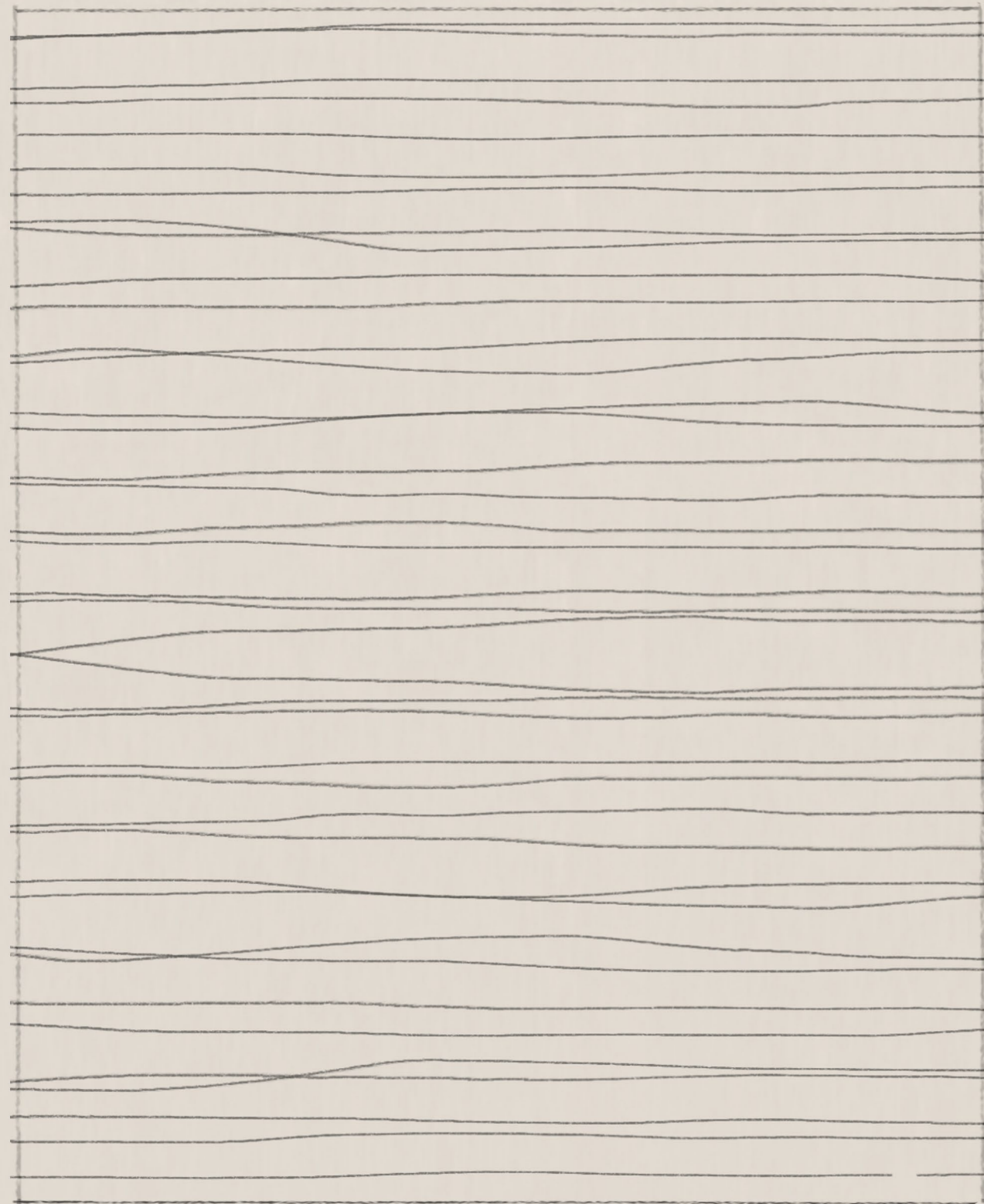

Un'estetica che si basa sulla sofisticata combinazione tra i volumi monomaterici dei piani lavabo e dei contenitori, ottenuta da una perfetta unione a 45° degli elementi, e una delicata texture geometrica delle superfici, ispirate ai pattern tessili e naturali. La collezione prevede diverse versioni dei piani: monomaterico, con lavabo integrato in pietra, o con sottolavabo in Milltek gel.

An aesthetic based on the sophisticated combination of the washbasin tops and containers' single-material volumes, obtained through a perfect 45° union of the elements, and the delicate geometric texture of the surfaces, inspired by textile and natural patterns. The collection includes a variety of tops, including those made of a single material, those with a built-in stone washbasin, and those with Milltek gel vanity unit.



Ispirato alla massima essenzialità, il carattere di Azuco è valorizzato dalla lavorazione a 45° e dalla particolare texture della superficie in marmo.

Inspired by maximum essentiality, the character of Azuco is enhanced by the 45° machining and the special texture of the surface in marble.



Azucò marmo Bianco Siberia  
Top integrato e basi sospese in marmo Bianco Siberia. Basi a terra in Rovere Miele. Specchiera contenitore semi-incasso con illuminazione led. Rubinetteria Flow L02 in acciaio inox satinato.

Azucò marmo Bianco Siberia  
Integrated top and wall-hung base units in Bianco Siberia marble. Floor-standing base units in Rovere Miele. Semi-recessed mirror cabinets with LED lighting. Flow L02 taps in brushed stainless steel.





Azucò prevede versioni monomateriche in marmo Bianco Siberia e Petit Granit. Disponibile anche la versione con lavabo sottopiano in Milltek Color Gel.

Azucò provides single material versions in white Siberia marble and Petit Granit. Also available the version with undermounted washbasin in gel-coloured Milltek.

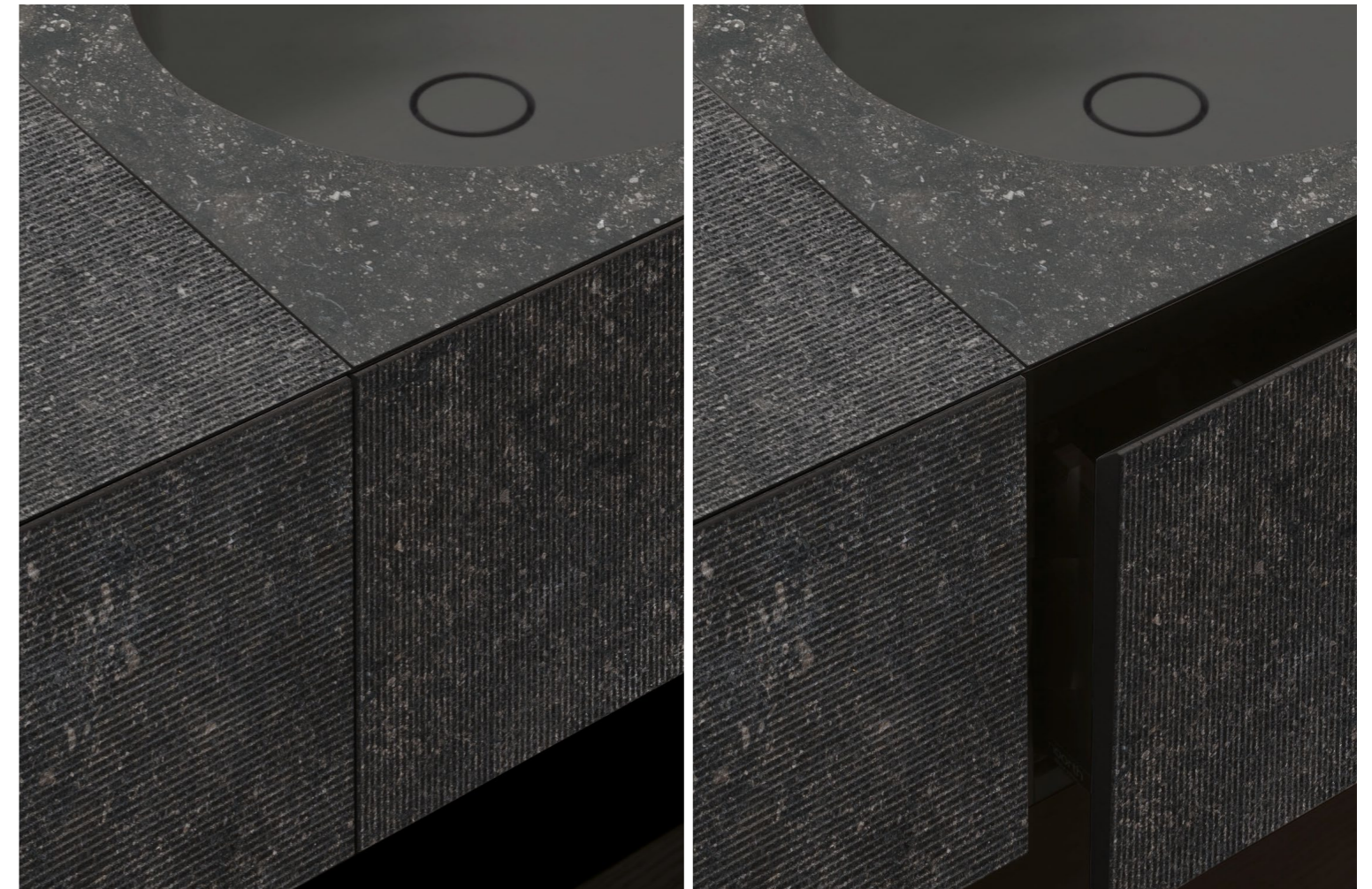

Azucò Marmo Petit granit  
Lavabo sottopiano in Milltek Gel laccato Grafite. Top e basi in marmo Petit granit alzatina con mensola in Rovere Carbone. Top sospeso in Rovere Carbone. Specchiera Vetra con retroilluminazione LED quattro lati e profilo anodizzato nero. Rubinetteria Flow L01 in acciaio inox satinato. Tappeto Lidi 04-W. Vasca Azuma 85 in Cristalplant laccato grafite, vassoi loto in Rovere Carbone. Paravento Levante in Rovere Carbone. Rubinetteria Flow V01 in acciaio inox satinato.

Azucò Marmo Petit granit  
Undermounted washbasin in Milltek Gel lacquered Fango. Top and base units in Petit granit marble, splashback with shelf in Rovere Carbone. Suspended top in Rovere Carbone. Vetra mirror with four-sided LED backlighting and black anodised profile. Flow L01 taps in brushed stainless steel. Lidi 04-W carpet. Azuma 85 bathtub in Cristalplant lacquered Fango. Loto trays in Rovere Carbone. Levante screen in Rovere Carbone. Maki pouf in black cork. Flow V01 taps in brushed stainless steel.





## UN NUOVO SISTEMA DI CONTENITORI | A NEW CONTAINER SYSTEM

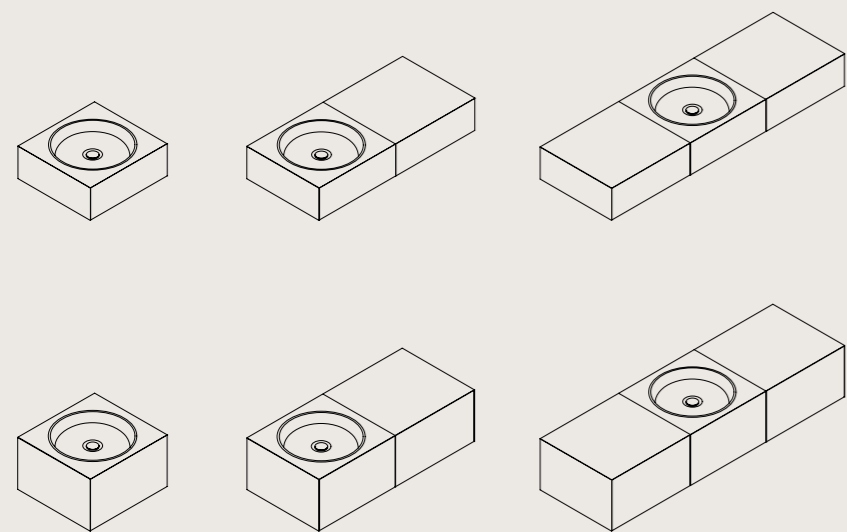

Componibile in larghezza e disponibile in 2 altezze: 20cm e 32cm, Azuco si presenta con un'immagine rigorosa e minimale, caratterizzata dalla lavorazione delle superfici a 45°.

Modular in width and available in 2 heights: 20cm and 32cm, Azuco presents itself as rigorous and minimal, characterized by the workmanship surfaces at 45°.

## LIBERTÀ NELLA COMPOSIZIONE GRAFICA | FREEDOM IN GRAPHIC COMPOSITION

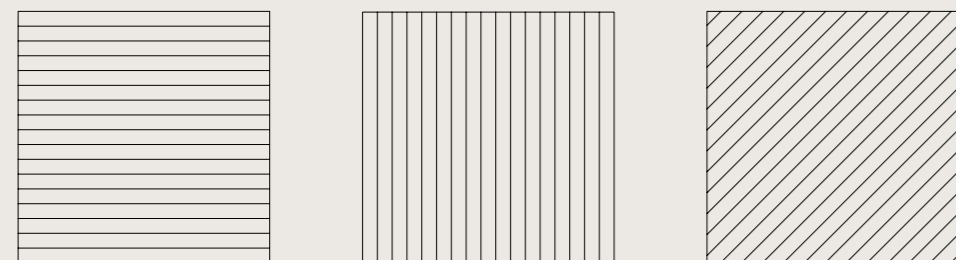

La delicata lavorazione delle superfici dei moduli Azuco è prevista nei sensi orizzontale, verticale e diagonale, tra loro liberamente configurabili.

The delicate processing of the surfaces of the Azuco units, is provided in horizontal, vertical and diagonal directions, freely configurable between them.

## LAVABO INTEGRATO, FINITURE | INTEGRATED WASHBASIN, FINISHES

new

marmi | marbles

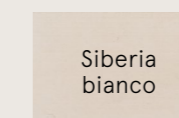
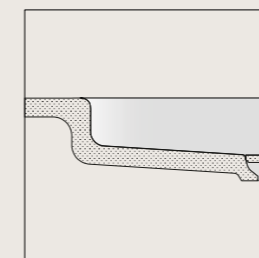

Originale nel disegno e nella profondità, il lavabo in versione monomaterica è ricavato dalla lavorazione di un unico blocco di marmo.

Original in design and depth, the washbasin in a single-material version is obtained from the processing of a single block of marble.

## LAVABO SOTTOPIANO, FINITURE | UNDERMOUNTED BASIN, FINISHES

top | top  
marmi | marbles

lavabo | washbasin  
Milltek Color Gel | gel-colored Milltek

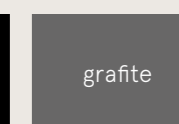
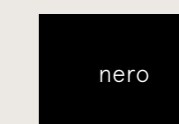
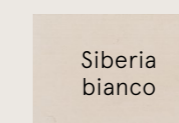
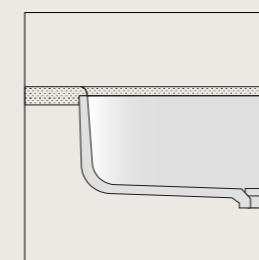

Accuratamente integrato al piano in marmo, il lavabo in Milltek Color Gel è disponibile in 4 varianti colore, rispettivamente abbinato al marmo stesso.

Carefully integrated with the marble countertop, the washbasin in Milltek Color Gel is available in 4 color variants, respectively matching the marble itself.

# Puro

design Michele Marcon

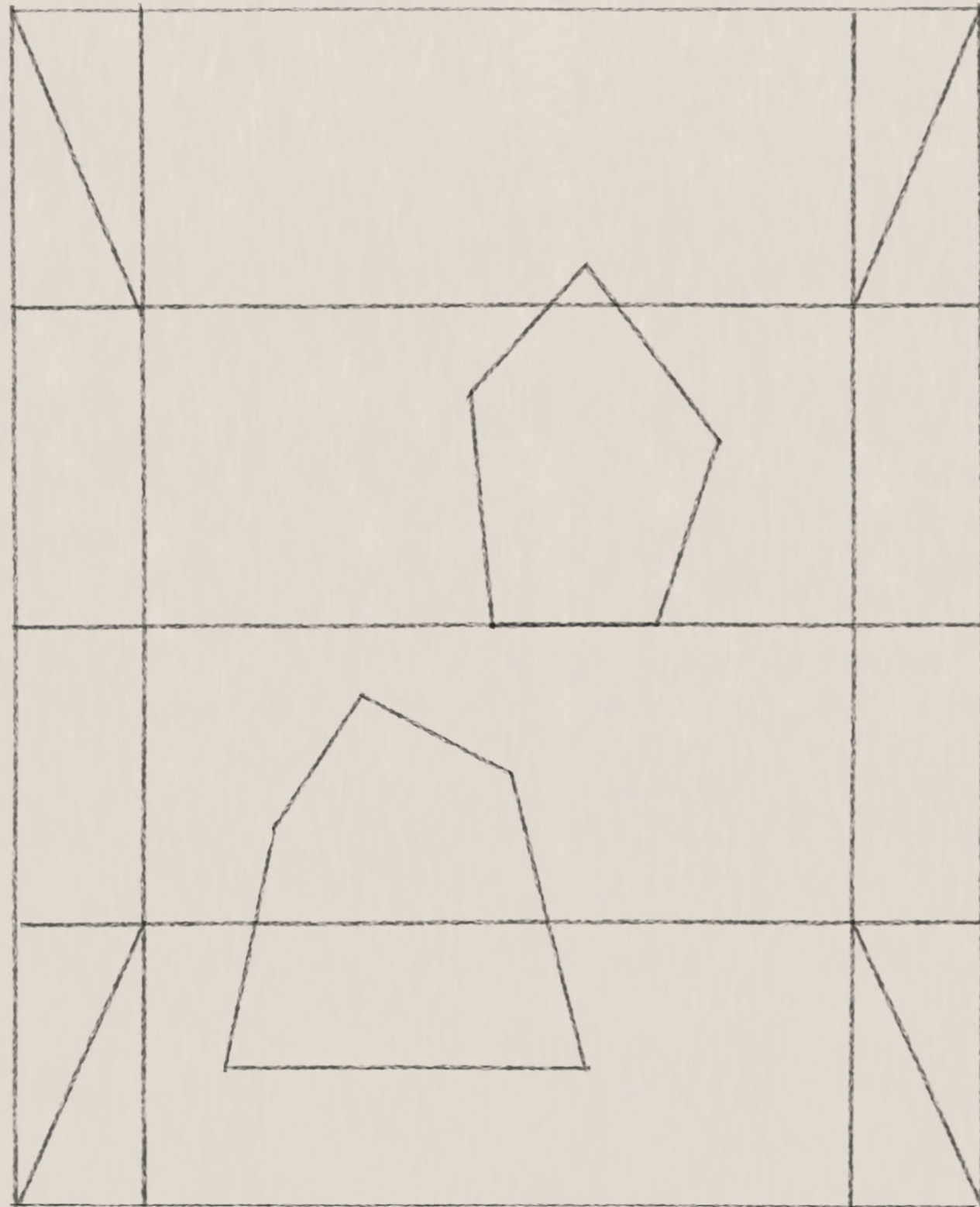

Un design rigoroso fatto di superfici preziose e geometrie perfette, sottolineate dalla lavorazione a 45° di piani e contenitori e dall'assenza della maniglia, sostituita dalla gola. La collezione è arricchita da un inedito fianco laterale in vetro per le basi e dalle colonne a giorno con luce integrata.

A rigorous design made of precious surfaces and perfect structures, underlined by the 45° working of the tops and the units and by the absence of the handle, replaced by the groove. The collection is enriched by an unprecedented glass side panel for the bases and by the open elements with integrated light.



Soluzione di forte originalità, il nuovo contenitore laterale con fianco in vetro permette di “alleggerire” il volume delle basi e di impreziosirne l’immagine.

A solution of strong originality, the new lateral unit with the glass side, allows you to “lighten” the volume of the bases and to embellish the image.



Lavabo in appoggio Step 63.14 in Cristalplant. Top, basi e fianchi a 45° in Rovere Termocotto. Base a giorno con illuminazione LED, vetro fumè e dettagli in Rovere Termocotto. Mensole Ljos in alluminio laccato Basalto, complete di accessori, con retroilluminazione a LED. Specchiera Prisma a soffitto. Tappeto Lidi 01-B. Piatto doccia Line in Milltek Solid. Rubinetteria Flow in acciaio inox PVD nero. Colonne in Rovere Termocotto con apertura gola a 45°. Colonna a giorno con ripiani e schienale in Rovere Termocotto.

Step 63.14 sit-on washbasin in Cristalplant. Top, base units and 45° side panels in Rovere Termocotto. Open base unit with LED lighting, smoked glass and Rovere Termocotto details. Ljos shelves in lacquered aluminium Basalto, complete with accessories, with LED backlighting. Prisma ceiling mirror. Lidi 01-B carpet. Line shower tray in Milltek Solid. Flow tap in black PVD stainless steel. Columns in Rovere Termocotto with 45° groove opening. Open column with shelves and back panel in Rovere Termocotto.



## CONTENITORE LATERALE CON FIANCO IN VETRO | BASE UNIT WITH GLASS SIDE

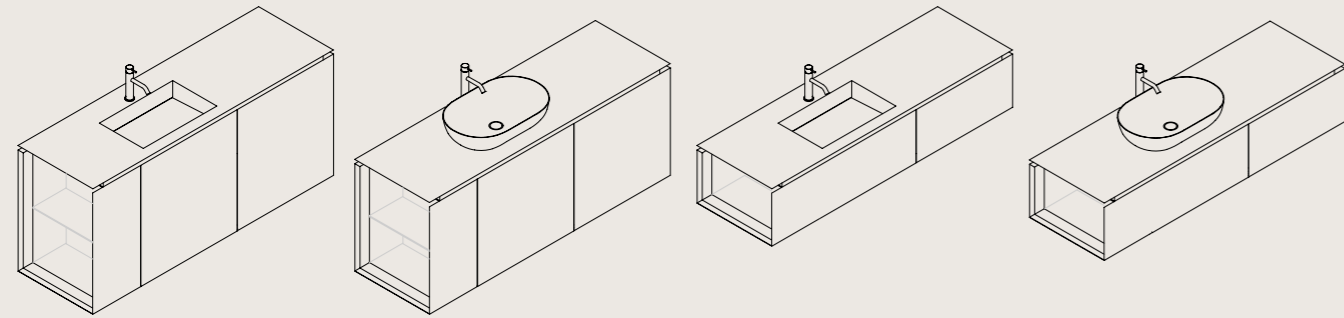

Previsto in 3 altezze, nelle versioni a terra h.72 e 81,2 e sospesa h. 35,5, il nuovo contenitore è dotato di illuminazione led interna.

Provided in 3 heights, 72 and 81 for the floor version and height 35,5 for wall standing units, the new base is equipped with internal LED lighting.

## I SISTEMI DI APERTURA | THE OPENING SYSTEMS

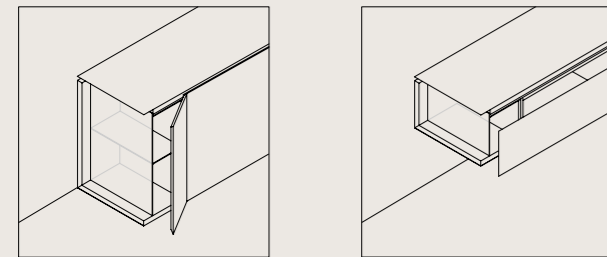

Con anta nelle versioni a terra o cassetto nella versione sospesa: varia il sistema di apertura del vano interno in funzione dell'altezza delle basi.

With door in the floor-standing versions or drawer in the suspended version: the opening system of the inner compartment change according to the height of the bases.

## CONTENITORI A COLONNA CON VANI A GIORNO | COLUMN UNIT WITH OPEN SHELVES



Il sistema di contenitori a colonna si arricchisce di un nuovo elemento con vani a giorno, interamente il legno e dotato di illuminazione led integrata.

The column system is enriched with a new element with open compartments, entirely made of veneer and equipped with integrated LED lighting.

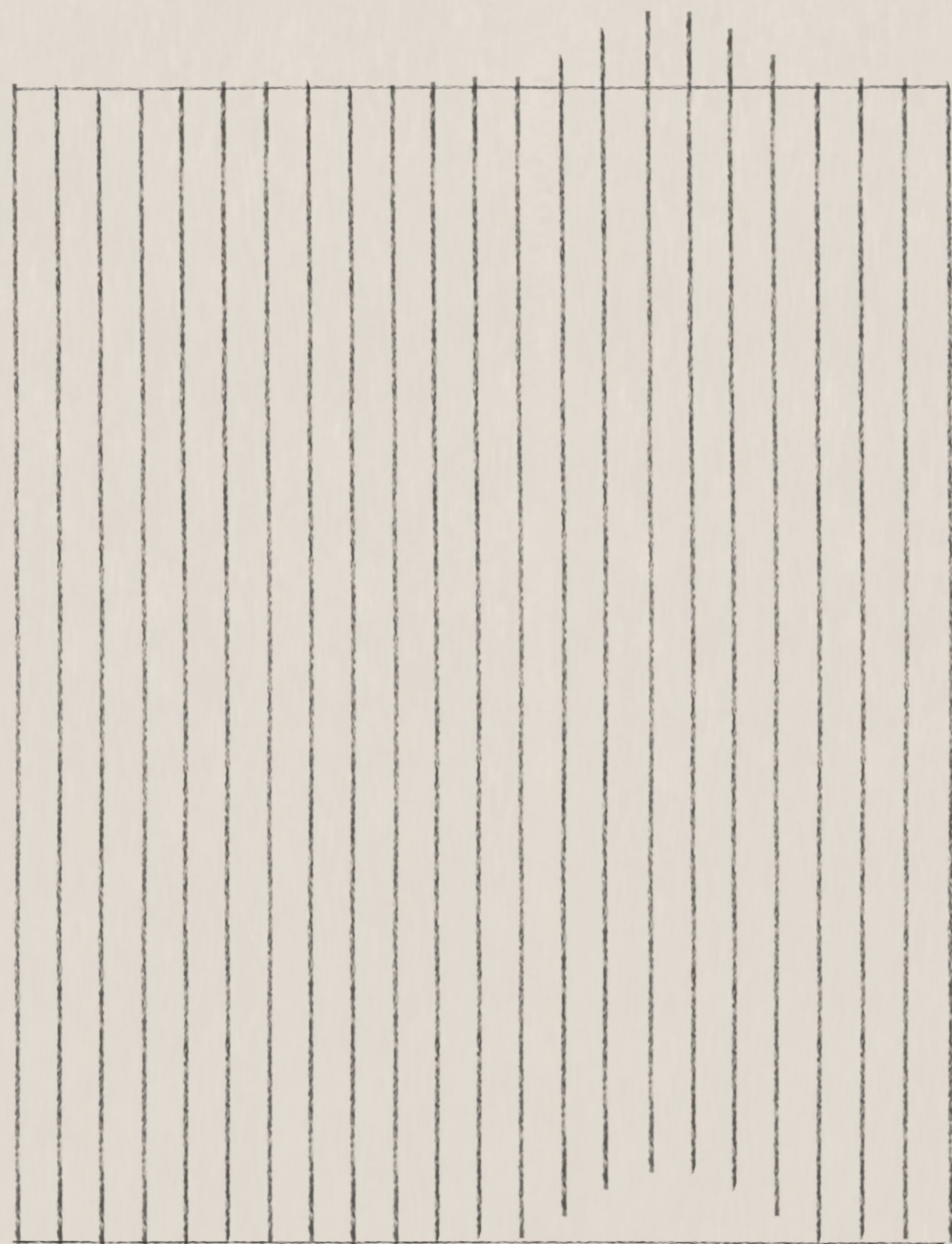

# Sintesi

design Michele Marcon

Un sistema reso straordinariamente flessibile dalla varietà dimensionale degli elementi e delle soluzioni previste per l'apertura dei contenitori, disponibili con gola, push&pull o maniglia. La collezione si arricchisce del fianco laterale, oggi disponibile in tutti i materiali e finiture del sistema, e l'anta Reki, prevista in Noce Canaletto o in laccato opaco.

A system made extraordinarily flexible by the dimensional variety of the elements and solutions provided for the containers, available with groove, push-pull or handle opening system. The collection is enhanced by the side panel, now available in all the materials and finishes of the collection, and the River door, available in Noce Canaletto or matt lacquer.





La continuità di materiale tra il top e il fianco e la nuova anta Reki ottenuta da una leggera incisione verticale della superficie, suggeriscono un'interpretazione di Sintesi elegante e sofisticata.

The continuity of material between the top and the side and the new Reki door, achieved by a slight vertical engraving of the surface, suggest an interpretation of Sintesi that is elegant and sophisticated.



Lavabo in appoggio Roma 16 in ceramica bianca opaca. Top e fianchi in gres Laminam Matera Stone Fiammato. Basi con anta Reki in Noce Canaletto. Specchiera Leno con retroilluminazione LED e sabbiatura perimetrale. Rubinetteria Flow L01 in acciaio inox satinato. Contenitori Caba in Venato Sesamo. Tappeti Plain 02-W.

Sit-on washbasin Roma 16 in matt white ceramic. Top and sides in Laminam Matera Stone Fiammato gres. Base units with Reki door in Noce Canaletto. Leno mirror with LED backlighting and sandblasting perimeter. Flow L01 taps in brushed stainless steel. Caba storage units in Venato Sesamo. Plain 02-W carpet.



## REKI, LA NUOVA ANTA | REKI, THE NEW DOOR

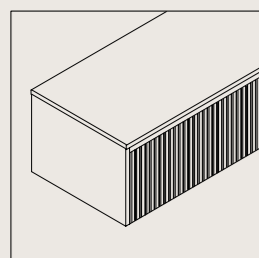

SINTESE

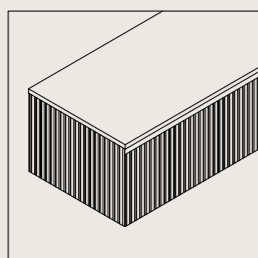

ZENIT

Ottenuta da una leggera incisione verticale della superficie, l'anta Reki rappresenta una nuova soluzione estetica per le collezioni Sintesi e Zenit.

Obtained by a slight vertical engraving of the surface, the Reki door represents a new aesthetic solution for the Sintesi and Zenit collections.

## REKI, LE FINITURE | REKI FINISHES

essenze | veneers

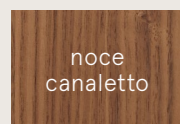

noce  
canaletto

laccati opachi | matt lacquered

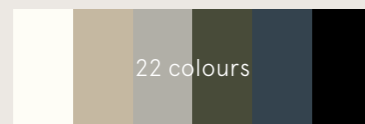

22 colours

Oltre alla versione laccato opaco nei 22 colori della collezione, l'anta Reki è disponibile nell'essenza più preziosa: il Noce Canaletto.

In addition to the matt lacquered version in the 22 colours of the collection, the Reki door is available in the most precious veneer: Noce Canaletto.

## NUOVE FINITURE PER I FIANCHI | NEW FINISHES FOR ALL SIDES

top, fianchi | tops, sides

sintetici | compounds



marmi opachi | matt marbles

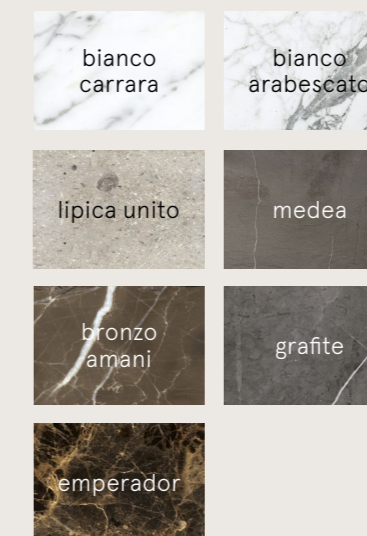

Gres Laminam



\*opachi e lucidi | matt and glossy

L'introduzione di tutte le finiture sul fianco laterale consente di completare i lati delle composizioni in modo uniforme rispetto al top.

The introduction of all the finishes on the side panel allows the sides of the compositions to be evenly completed with respect to the top.

# Touch

design Michele Marcon

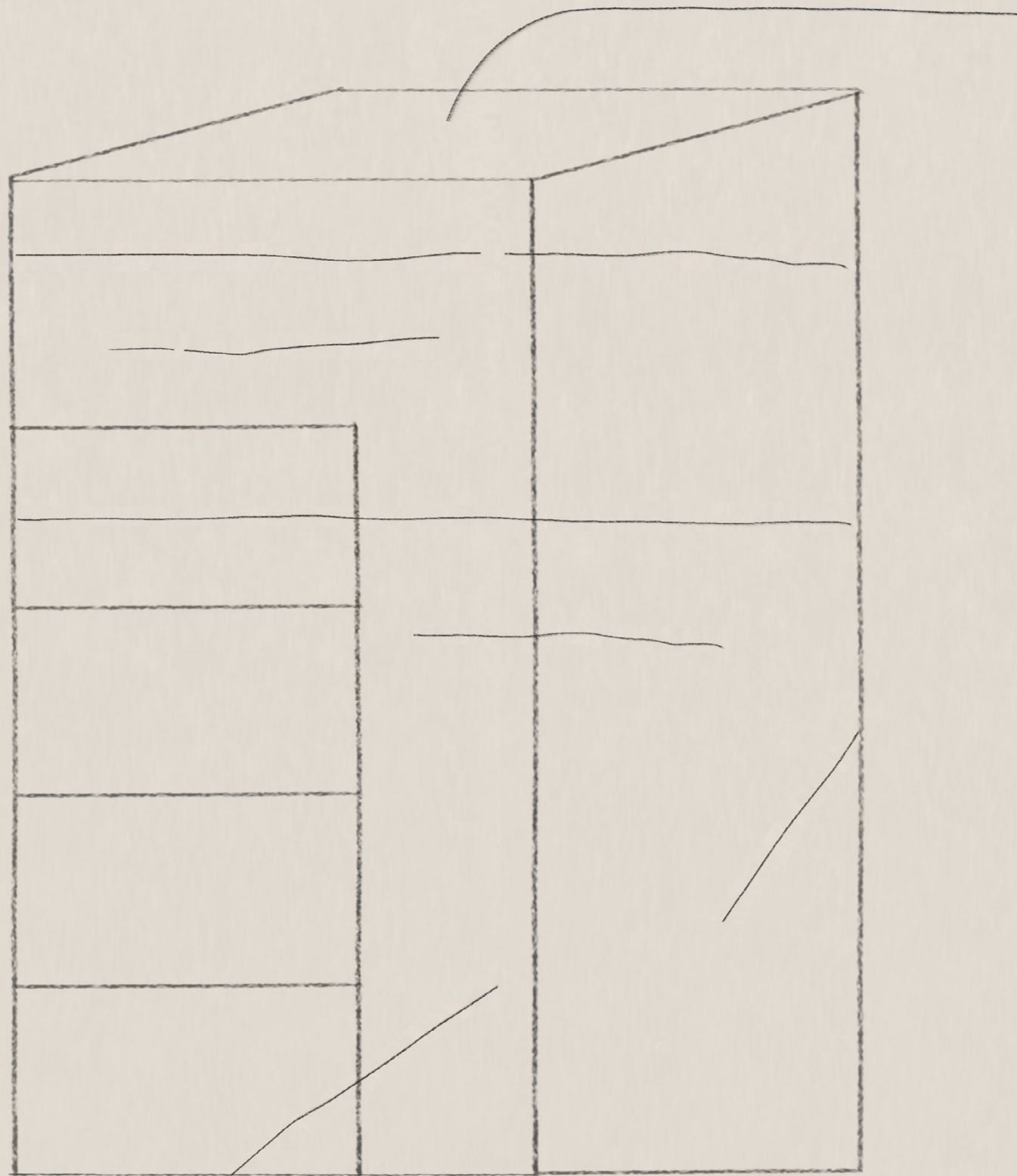

Un lavabo monolitico dall'estetica minimale, in grado di conferire identità e personalità anche a spazi di piccole dimensioni. Touch è disponibile in un'ampia varietà di finiture: dai marmi alle laccature, fino ai legni e le argille. Una proposta dall'impronta contemporanea, sottolineata dalla combinazione con le specchiere dotate di illuminazione led integrata.

A monolithic washbasin with a minimal aesthetic, able to give identity and personality even to small spaces. Touch is available in a wide variety of finishes: from marbles to lacquers, to woods and clays. A proposal with a contemporary imprint, underlined by the combination with the mirrors equipped with integrated LED lighting.



Un'estetica rigorosa e compatta svela inaspettati spazi per il contenimento. La preziosità di Touch è sottolineata dall'accurata lavorazione di ogni dettaglio.

A rigorous and compact aesthetic reveals unexpected storage spaces. The preciousness of Touch is underscored by the careful workmanship of every detail.



Basi predisposte per scarico a pavimento con lavabo full 41 in marmo Carrara. Specchiera Vetra con retroilluminazione LED quattro lati. Rubinetteria in acciaio inox satinato.

Base units arranged for floor drainage with full 41 Carrara marble basin. Vetra mirror with four-sided LED backlighting. Brushed stainless steel taps.

art direction  
Paolo Mojoli

graphic design  
Juma

photos  
F2 Fotografia

rendering  
Nerokubo

edition  
September 2022

Milldue spa si riserva il diritto di apportare modifiche migliorative al prodotto in qualsiasi momento e senza preavviso. I campioni dei materiali sono a carattere puramente indicativo. | Milldue reserves the right to apply improving changes to the products at any time without prior notice. The samples are purely indicative. | Milldue se réserve le droit d'apporter modifications pour l'amélioration du produit, à n'importe quel moment et sans préavis. Les échantillons sont à caractère purement indicatif. | Milldue spa behält sich das Recht vor, zweckmäßige verbessernde Änderungen der Produkte ohne Voranmeldung vorzunehmen. Die Muster sind unverbindlich. | Milldue оставляет за собой право в любой момент и без предупреждения усовершенствовать характеристики своих изделий. Образцы имеют исключительно ориентировочное значение.

noorth

marchio registrato  
registred trademark  
marque déposée  
eingetragene Marke  
заводская марка

**milldue**

milldue spa © 2013 All rights reserved

MILLDUE SPA  
sede legale: Via Balegante 7 - 31039 Riese Pio X - Treviso - Italy  
sede operativa: Via dell'Economia 6 - 31033 Castelfranco Veneto - Treviso - Italy  
P. I. 00544260268 - tel +39 0423 756611 - fax +39 0423 756699  
www.milldue.com - milldue@milldue.it

